

Combustion Efficiency Analyzer

709R



The Value Leader™

www.tpi-thevalueleader.com

Contents

1. Introduction
 2. General Overview
 3. Instrument Overview
 - 3.1 Front View
 - 3.2 Back View
 - 3.3 Side Views
 - 3.4 Top View
 4. Basic Analyzer Controls
 - 4.1 Turning The Analyzer On
 - 4.2 Turning The Analyzer Off
 - 4.3 Charging The Analyzer
 - 4.4 Activating The Backlight
 5. Combustion Analysis Overview
 - 5.1 Procedure
 - 5.2 Combustion Displays
 - 5.3 Typical Test Locations
 - 5.4 Typical Test Results
 6. Function Selection
 - 6.1 Function 1 - Thermometer
 - 6.2 Function 2 - Manometer
 - 6.3 Function 3 - Date / Time
 - 6.4 Default Function - Combustion Analyzer
 7. Saving Data
 8. Recalling Data
 9. Printing Data
-
- Appendix A Specifications
 - Appendix B Calibration & Service
 - Appendix C Guarantee
 - Appendix D Installing the Optional A773 Filter
 - Appendix E Error Codes and Trouble Shooting
 - Appendix F CO Alarm & Auto Power Off Settings
 - Appendix G Manually Initializing Sensors
 - Appendix H Resetting Pressure Sensor Zero
 - Appendix I Technical Notes

1. Introduction

Thank you for purchasing TPI brand products. The TPI 709R Flue Gas Analyzer is a state of the art, easy to use analyzer designed not only to display and calculate the required readings from a flue but also to cover most of the other measurements associated with combustion. The instrument is ruggedly constructed and comes with a 3 Year unit and 2 Year sensor Guarantee.

2. General Overview

The TPI 709R combustion analyzer uses state of the art electrochemical sensors. This sensor technology provides the longest lasting, most accurate and reliable means for performing combustion tests. The sensors in your analyzer will need to be replaced periodically and calibration is recommended once every year.

Electrochemical sensors by nature are always active. Therefore the time the analyzer is off and not being used must be taken into account when determining sensor life. The sensors in your analyzer are warranted for two years. This warranty does not cover sensors damaged through misuse of the analyzer.

You should keep the batteries of your 709R fresh so power is constantly being supplied to your sensors.

The following guidelines will help prevent damage to your sensors:

Always use the mini pump filter when testing flue gases.

Always periodically check and replace the mini pump filter as needed.

Always make sure the in-line filter / water trap is installed properly.

Always periodically check and replace the in-line filter as needed.

Always remove water or condensation from the inside of the in-line filter / water trap assembly prior to performing tests.

Always use the optional oil filter (p/n A773) when performing tests on oil burning equipment.

General Overview (Continued)

Never over saturate your sensors by performing tests on equipment with gas levels beyond the capability of you analyzer.

Always keep the A794 water trap / filter assembly clean and replace the filter as necessary. Replacement filter part number is A794F.

This manual will guide you through the functions of the TPI 709R which will give you many years of reliable service.

Your TPI 709R Flue Gas Analyzer comes complete with the following standard accessories:

- TPI 709R Instrument
- Rubber Boot (A765)
- Battery Charger (A766) - 1 each
- Soft Carrying Case (A787)
- Flue Sampling Probe (A770)
- In-Line Filter assembly installed on Flue probe (A795)
- Temperature Probe (GK11M)
- Pressure Tubing (A774) - 1 each 6' piece
- Mini Pump Protection Filter Assembly and spare filters (A763)
- Exhaust Spigot (removable) (A764)
- Instruction Manual

() Denotes part number

Your TPI 709R Flue Gas Analyzer has the following options available:

- Infrared printer (A740)
- Spare In-Line Filter (A794F is a package of 5 filters)
- Water filter in water trap (A794W)

3. Instrument Overview

3.1 Front View



Rubber Boot	Protects the instrument from accidental damage
Display	Large 3 Parameter Backlit LCD Display
Battery Condition Icon	Shows condition of batteries.
Keypad	Selects all available functions
Selected Fuel Type	N GAS, LPG, LIGHT OIL, HEAVY OIL, OPT 1 (Bituminous Coal), OPT 2 (Anthracite Coal), OPT 3 (Coke), OPT 4 (Butane), OPT 5 (Wood), OPT 6 (Bagasse)

NOTE: When selecting oil as fuel be sure to use the optional oil filter (A773) or readings could become erratic. See Appendix E for installation instructions.



Scrolls through selectable fuels (see 3.1)
Switches between Gross and Newt Efficiency (see 4.1.2)
Switches between °C and °F (see 4.2.1)
Moves up through the Stored Data Addresses (see 5, 6 & 7)



Moves down through the Stored Data Addresses (see 5, 6 & 7)



Scrolls through Combustion Analysis Displays
Scrolls through Function Screens (see 4.1)
Turns temperature differential calculation ON/OFF (see 4.2.1)
Turns ch2 temperature ON/OFF (see 4.3.1)
Allows you to change the Date and Time (see 4.5)
Allows you to choose a Stored Data Address (see 5, 6, 7, & 8)



Sends stored data to a separate infrared printer (see 7)



Allows you to view stored data on the display (see 6)



Stores readings to memory (see 8)



Scrolls through and selects analyzer functions (see 4)
Turns Backlight ON and OFF (see 4)



Turns the instrument ON and OFF (see 3.1 & 3.2)

3.2 Back View

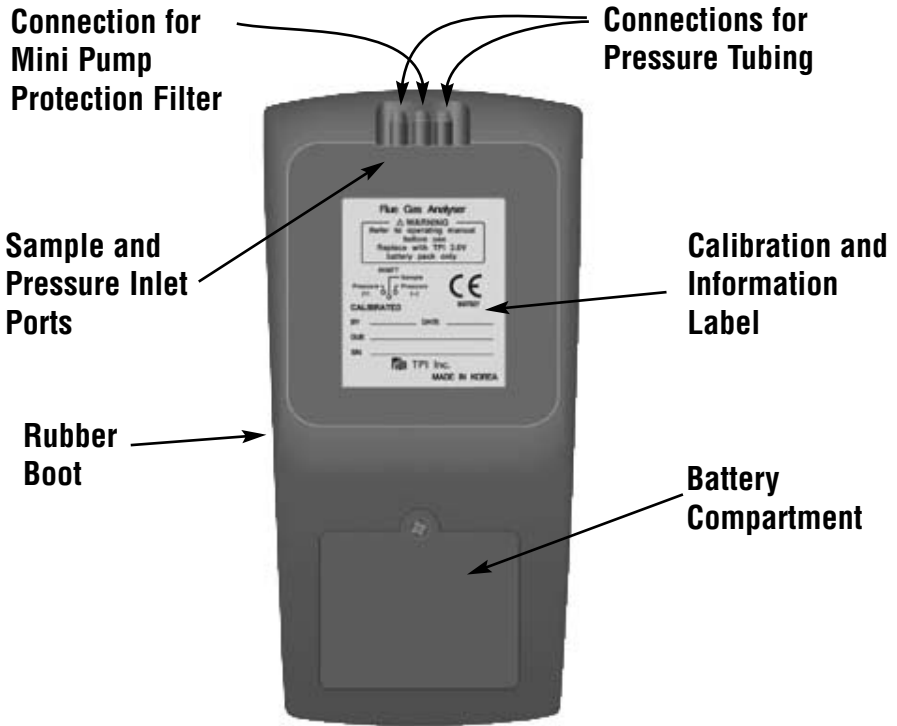

Sample and Pressure Inlet Ports: Connection for Gas Sampling Probe (see 3.4, 5.2, 6.2)

Connection for Mini Pump Protection Filter (see 3.4 & 6.2)

Connections for Pressure Tubing: (see 3.4 & 6.2)

Calibration and Information Label: Displays calibration information and Displays serial number

Battery Compartment: Holds batteries

Rubber Boot Protects the instrument

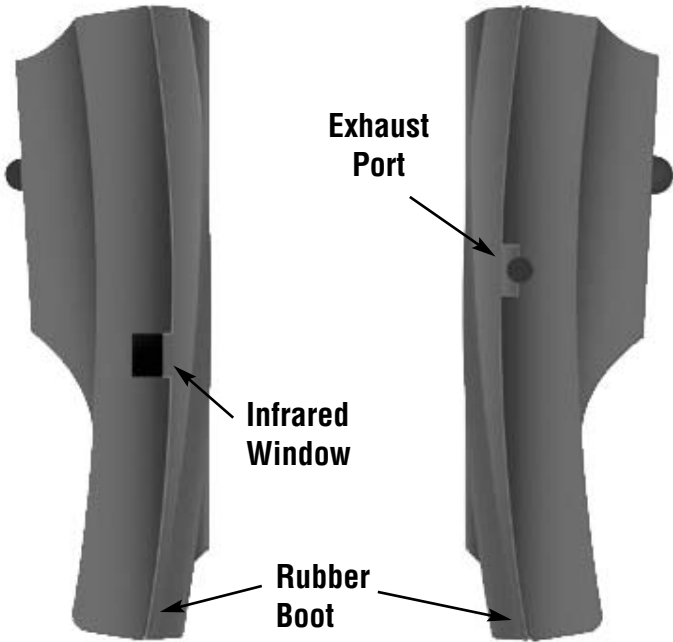

3.3 Side Views

Exhaust Port

Port for connection of Exhaust Adapter

Infrared Window

Window for sending stored data to IR Printer
(see 9)

Rubber Boot

Protects the instrument from accidental damage

3.4 Top View

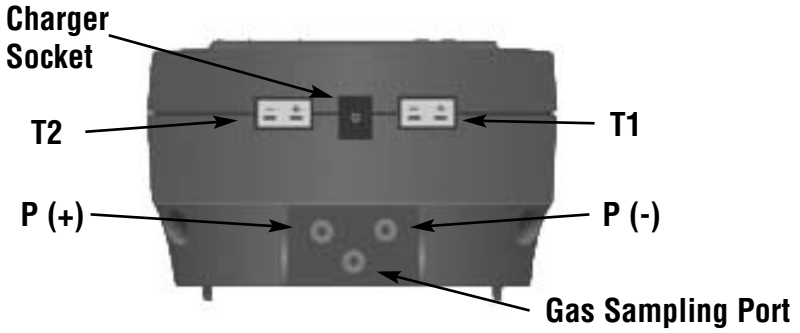

- Charger Socket** Connection for 220V/115V charger (see 4.3)
- T1 Socket** Connection for thermocouple plug on flue probe (see 5.2)
Connection for any 'K' type thermocouple probe (see 6.1)
- T2 Socket** Connection for any 'K' type thermocouple probe (see 5.2 & 6.1)
- Gas Sample Port** Connection for Gas Sampling Probe (see 5.2)
- P (+) Port** Connections for Pressure Tubing (see 6.2)
- P (-) Port** Connections for Pressure Tubing (see 6.2)

4. Basic Analyzer Controls

4.1 Turning The Analyzer On

Always: - Before turning on please ensure that the Mini Pump Protection Filter assembly and the Temperature Sampling Probe complete with In-Line Filter or the Tubing & In-Line Filter for Leak Detection are **not** connected to the Gas Sample Port (see 2.2 or 2.4)

Press and hold down the Power Key and the TPI 709R will start its 30 second countdown 'PURGE' will be displayed: - The instrument **MUST** be turned on in a clean air environment as the 30 second purge will set the Carbon Monoxide level to Zero and the Oxygen to 20.9%.

Ensure that the filters are clean and dry as dirty or wet filters will result in a loss of flow rate and 'Lo Flo' will be displayed to inform you that filters should be changed

During the last 20 seconds of the 30 second purge time the user can scroll through the following Fuels: - Natural Gas, LPG, Light Oil, Heavy Oil, OPT1 : Bituminous Coal, OPT 2 : Anthracite Coal, OPT 3: Coke, OPT 4: Butane, OPT 5: Wood (Dry), OPT 6: Bagasse by pressing the Up Arrow Key to select the Fuel they are working with. When desired fuel is displayed release the key, displayed fuel is now selected.

After the 30 second countdown the instrument is ready to take Flue, Temperature, Pressure or Leak Detection readings and Combustion Display 1 will be the first display.

The 709R will auto power off if no keys have been pressed for 10 minutes and the CO level is below 15ppm. This feature can be disabled see Appendix F.

The Scroll/Enter Key allows you to scroll through the combustion displays as outlined in section 5.3. The Func Key is used to select the 709R function mode and allows you to set it to be a combustion analyzer, manometer, thermometer, or combustible leak detector. In addition, the Func Key is used to access the date and time display. See section 6 for more information on the Func Key.

NOTE: When selecting oil as fuel be sure to use the optional oil filter (A773) or readings could become erratic. See Appendix E for installation instructions.

4.2 Turning The Analyzer Off

Always: - Before turning off return the instrument to a clean air environment and allow the Carbon Monoxide level to return to below 15ppm and the Oxygen level to return to 20.9% ($\pm 0.3\%$) Press the Power Key to turn the instrument off:- NOTE Should you attempt to turn the instrument Off and the CO reading is above 15ppm then the instrument will remain On and a short Beep will be heard. The Instrument can only be switched off if the CO is below 15ppm

The instrument has an auto shut off after 10 minutes should no keys have been pressed for this period and as mentioned above that the CO is below 15ppm. Should the CO be above 15ppm then the 10 minute auto shut off countdown will not begin till the CO has gone below 15ppm

4.3 Charging The Analyzer

Plug the Charger supplied into the charger socket on the instrument (see 3.4). If the instrument is turned on then a charging symbol will be displayed. Should the instrument then be turned off, turn off automatically or be turned off when the charger is plugged in then the charging symbol will not be displayed BUT the instrument will still be charging.

The instrument should be charged overnight for a period of 10 to 12 hours and will give over 6 hours Operating Time. If a beeping noise is heard during charging disconnect the charger. This is an indication the battery pack needs to be replaced or of something wrong in the charging circuit. Please contact TPI technical assistance at 800-368-5719.

The 709RRR can be used while plugged into the charger even without a battery installed.

4.4 Activating the Backlight

The display backlight can be activated at any time by pressing and holding down the Func Key for approximately 2 seconds. The backlight will automatically shut off after approximately 20 seconds to preserve battery life.

5. COMBUSTION ANALYSIS OVERVIEW

Testing for carbon monoxide, oxygen, and stack temperature is very important to the overall safety and efficiency of heating equipment. The following guidelines and descriptions are generic and meant to provide you with a basic understanding of combustion testing. TPI always recommends you contact the manufacturer of the device under test, obtain information specific to the device, and follow the procedures and safety guidelines for performing tests and affecting repairs.

In general, for most applications flue gas samples should be taken prior to the draft diverter or any other opening that allows room air to enter the system. This prevents room air from mixing with gases in the flue and diluting the test sample. To ensure accurate and consistent combustion tests, it is important gas and temperature samples be taken at the same location. This is easy with the TPI flue probe because the temperature sensor is an integral part of the probe.

Prior to taking a sample, the device under test should be on and operating. Putting the flue probe in the sample area prior to starting the device may cause saturation of the sensors due to the higher initial concentration of carbon monoxide that may be encountered upon start up. If this happens, allow your analyzer to purge in fresh air until the carbon monoxide level returns to 0 ppm and the oxygen level returns to 20.9%. This may take more than an hour depending on how saturated the sensors are.

The included figures show locations for performing tests on commonly encountered equipment. Remember to consult with the manufacturer of the device under test for specific test information.

NOTE: When selecting oil as fuel be sure to use the optional oil filter (A773) or readings could become erratic. See Appendix E for installation instructions.

COMBUSTION ANALYSIS (Continued)

5.1 Procedure

1. Turn the 709R on as outlined in section 4.1. At any time you can activate the Backlight by holding down the Func/Backlight Key for 2 seconds. The backlight will automatically shut off after 20 seconds to preserve battery life.
2. Ensure you have connected the Mini Pump Protection Filter assembly and Temperature Sampling Probe complete with In-Line Filter to the Gas Sample Port (see 3.2 or 3.4) and the 'K' Type Thermocouple Plug into Thermocouple (T1) Socket (see 3.4). The GK11M ambient air temperature probe must be connected to the (T2) socket. (refer to figure below for correct hookup)

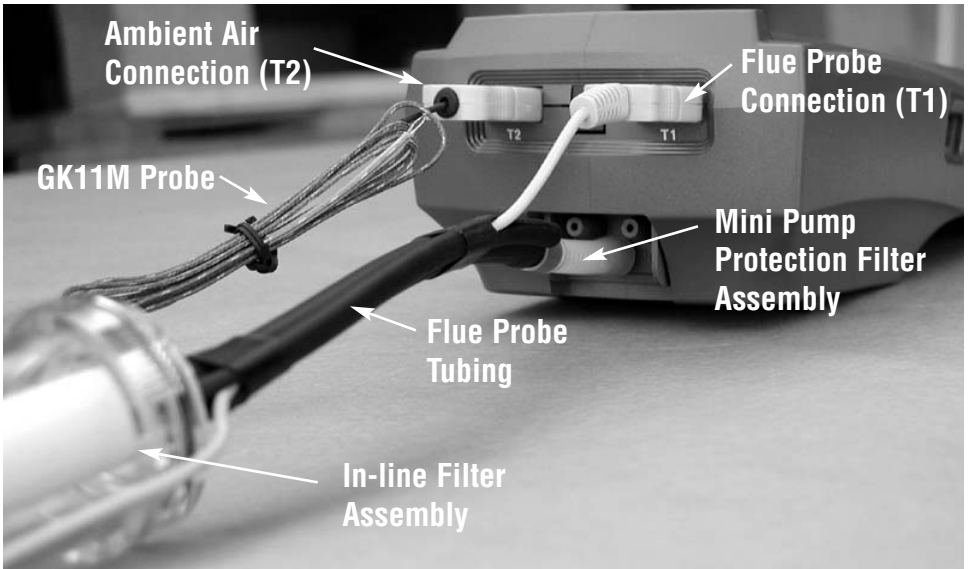

WARNING: - Ensure that the In-Line Filter hangs in a vertical position when readings are being taken, particularly if water is visible. Failure to comply may result in damage to the instrument.

WARNING: - There is ONLY one correct way to connect the 'K' type thermocouple plug into the socket (see 2.4). Forcing the plug into the socket the wrong way round may result in damage to the instrument.

3. Insert the flue probe into the test location of the device under test. The probe tip should be in the middle of the flue pipe or exhaust stream. Refer to figures 1 through 3 for typical test locations.

COMBUSTION ANALYSIS (Continued)

4. As seen below, use the Scroll/Enter Key to move through the various combustion displays.

5.2 Combustion Displays

You can move through the following Combustion Analysis Screens by repeatedly pressing Scroll/Enter:



- **Combustion Display 1 (Default Start Up Display)**
- Displays Carbon Monoxide (CO) reading in parts per million (ppm)
- Displays calculated Carbon Dioxide (CO₂) figure in percentage (%)
- Displays calculated CO/CO₂ (Ratio) figure

WARNING: - Should the CO reading rise above 2,000ppm a continuous series of Alarm Beeps will be heard. The Probe should immediately be disconnected from the instrument and the instrument returned to a clean air environment. This Alarm alerts the user that there is a high concentration of CO, and this procedure will protect the sensors within the instrument.



- **Combustion Display 2**
- Displays Oxygen (O₂) reading in percentage (%)
- Displays calculated Excess Air (X Air) figure in percentage
- Displays calculated Efficiency (Eff.) figure in percentage
- Pressing the Up Arrow Key will toggle between Gross & Net Efficiency (**Note: Gross Efficiency is used in the USA**)



- **Combustion Display 3**
- Displays Carbon Monoxide (CO) reading in parts per million (ppm)
- Displays Oxygen (O₂) reading in percentage (%)

COMBUSTION ANALYSIS (Continued)

5.2 Combustion Displays (continued)



- **Combustion Display 4**
- Displays CO air free (-CF-)



- **Combustion Display 5**
- Displays Temperature reading of Channel 1 (T1) in degrees Centigrade (°C)
- Displays Temperature reading of Channel 2 (T2) in degrees Centigrade (°C)
- Displays the Differential Temperature (Diff.) between ch1 and ch2 in °C
- 'oPEn' will be displayed if no 'K' type probe is connected to the thermocouple socket

5.. During a combustion test you can save, print, and send data to a computer. See section 7 through 11. Allow readings to stabilize before saving or printing the data.

6. After the test is complete, remove the flue probe from the test location and allow the analyzer to purge in a fresh air environment. Turn the analyzer off as outlined in section 4.2.

NOTE: When selecting oil as fuel be sure to use the optional oil filter (A773) or readings could become erratic.

COMBUSTION ANALYSIS (Continued)

5.3 TYPICAL TEST LOCATIONS

Atmospheric Gas Fired Fan Assist Boiler / Furnace

Typical Test Locations

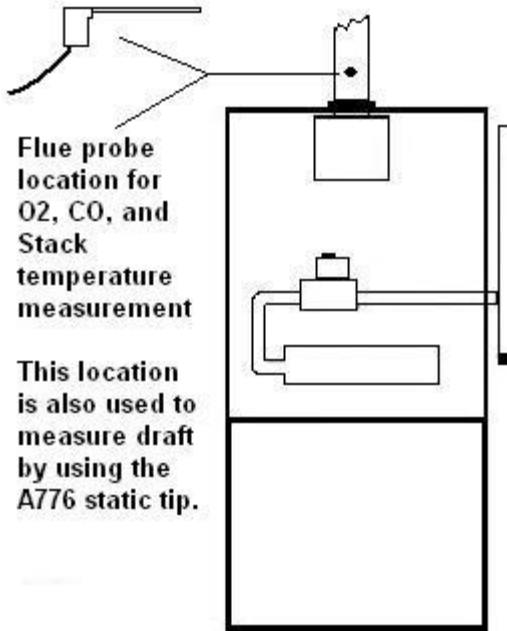

Figure 1

COMBUSTION ANALYSIS (Continued)

Condensing Boiler / Furnace

Typical Test Locations

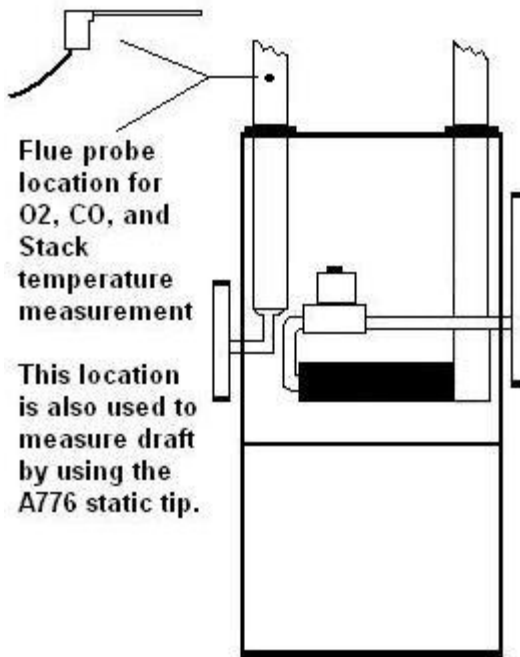

Figure 2

COMBUSTION ANALYSIS (Continued)

Atmospheric Forced Air Furnace

Typical Test Locations

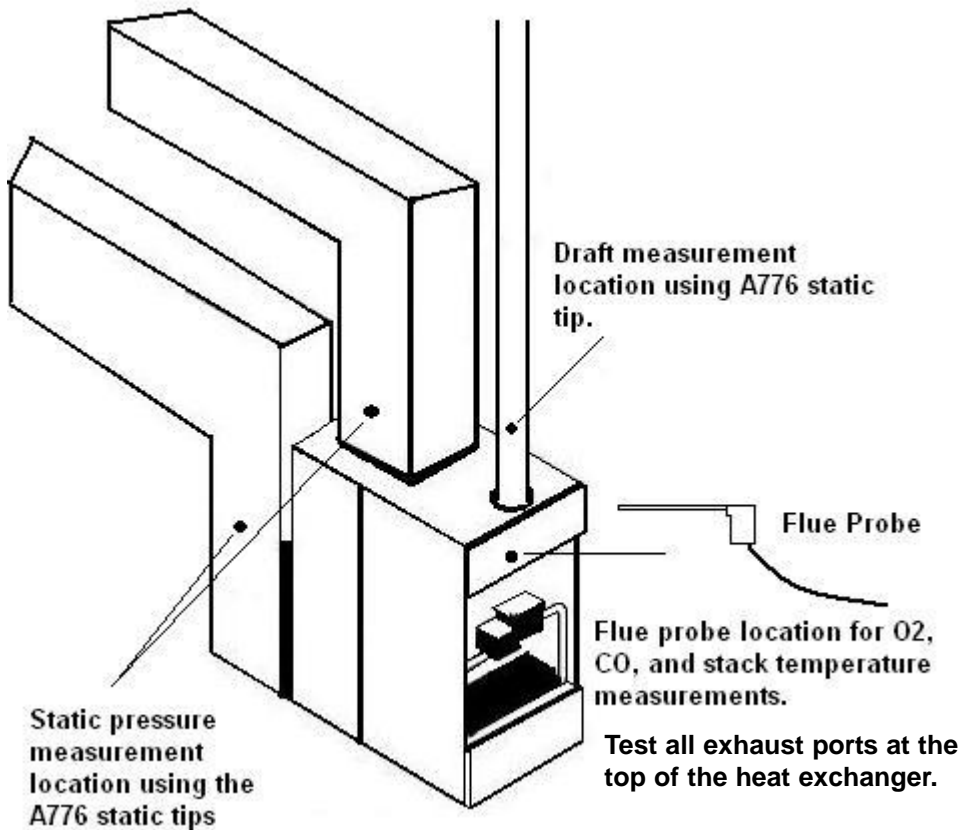

Figure 3

COMBUSTION ANALYSIS (Continued)

5.4 TYPICAL TEST RESULTS

Actual test results vary depending on the equipment under test. TPI recommends you check with the manufacturer of the equipment being tested to determine specific acceptable results.

Power Burners (Gas Fired)

Oxygen	3% to 6%
Carbon Monoxide	Less than 100ppm (air free)
Stack Temperature	300°F to 500°F
Draft	-0.15 inH ₂ O

Power Burners (Oil Fired)

Oxygen	4% to 7%
Carbon Monoxide	Less than 100ppm (air free)
Stack Temperature	325°F to 625°F
Draft	-0.15 inH ₂ O

Gas Fired Burners (Atmospheric / Fan Assist)

Oxygen	7% to 9%
Carbon Monoxide	Less than 100ppm (air free)
Stack Temperature	325°F to 500°F
Draft	-0.15 inH ₂ O to -0.4 inH ₂ O

6. FUNCTION SELECTION

Pressing the Func Key enables access to the different functions available on the 709R. Available functions are: Combustion Analyzer, Thermometer, Manometer, and Date / Time display.

6.1 Function 1: - Thermometer

Press the Func Key repeatedly to access the thermometer function. In this mode the 709R functions like a K-Type thermocouple thermometer. The pump will stop running when in this function.

The thermometer function allows you to perform temperature tests.



Function 1 Display (Temperature)

T1 Temperature
T2 Temperature
Differential Temperature

1. Ensure you have a 'K' type probe connected to one or both of the thermocouple sockets T1 or T2 (refer to figure below)

WARNING: - There is ONLY one correct way to connect the 'K' type thermocouple plug into the socket (see 4.2). Forcing the plug into the socket the wrong way may result in damage to the instrument.

2. Touch the temperature probe to the item under test and read the displayed



temperature.

Other Features:

- Pressing the Up Arrow Key will toggle between °C and °F
- Pressing the Scroll/Enter Key will toggle the Differential Temperature ON and OFF
- 'oPEn' will be displayed if no 'K' type probe is connected to the thermocouple socket

6.2 Function 2: - Manometer

Press the Func Key repeatedly to access the thermometer function. In this mode the 709R functions like a differential manometer. The pump will stop running when in this function.

The pressure function allows you to perform draft and pressure tests.



Function 2 Display (Pressure)
Pressure reading

1. Ensure you have Pressure Sampling Tube connected to one or both of the Pressure Ports and there are no restriction in the tubing (see figure below)



2. Zero the display by pressing the Down Arrow Key.

3. Connect the tube(s) to the device under test and read the pressure on the display.

Other Features:

- Pressing the Up Arrow Key will scroll through mbar, kPa and inH2O
- Pressing the Down Arrow Key will Zero the Pressure reading
- Pressing the Scroll/Enter Key will toggle the ch2 temperature reading ON and OFF

The 709R incorporates a differential manometer. This means when a single hose is connected to the (+) port and pressure is applied, the 709R will read positive pressure. If a single hose is connected to the (-) port and pressure is applied, the 709R will read a negative pressure. If both ports are connected to a pressure, the 709R will read the difference ($P1 - P2$) between the two.

6.3 Function 3: - Date/Time

Press the Func Key repeatedly to access the date/time screen. From this function Time, Date and Year can be changed.



Function 3 Display (Date / Time)

Time
Date / Month
Year

1. Once the Time, Date, and Year screen is displayed, press the Scroll/Enter Key once to allow you to change the data.
2. Press the Up Arrow Key to Increase the Minutes
3. Press the Down Arrow Key to Decrease the Minutes
4. Press the Scroll/Enter Key to confirm the desired Minute and move onto the Hours
5. Repeat steps 2 to 4 to change the Hour, the Day, the Month and the Year
6. The unit will return to normal after the desired Year has been confirmed

6.4 Default Function - Combustion Analyzer

Press the Func Key repeatedly to return to Combustion Analyzer mode and the default display (Combustion display 1)



- **Combustion Display 1 (Default Start Up Display)**
- Displays Carbon Monoxide (CO) reading in parts per million (ppm)
- Displays calculated Carbon Dioxide (CO₂) figure in percentage (%)
- Displays calculated CO/CO₂ (Ratio) figure

7. SAVING DATA

During testing data can be stored for later retrieval.

When data is saved, all data previously in the address will be overwritten. When saving pressure/draft readings, select an address different from the one used to save combustion readings.

1. Press the Store Key. *To cancel storing information press the Store Key and use the Up/Down Arrow Keys to select "Yes" and press the Scroll/Enter Key.*
2. "Addr" and an address location from 0 to 49 will flash on the display. Use the Up/Down Arrow Keys to select the desired location to store the data and press the Scroll/Enter Key. *To cancel storing information press the Store Key and use the Up/Down Arrow Keys to select "Yes" and press the Scroll/Enter Key.*
3. The data is stored and "End" will display. Use the Up/Down Arrow Keys to select "Yes" to stop storing data and return to normal operation or select "No" to store data again. Press the Scroll/Enter Key.

You have just successfully stored a set of readings which can be reviewed on screen (see 8) or sent to the IR printer (see 9)

8. RECALLING DATA

The recall feature allows you to display stored data or retrieve the last date of calibration.

Recalling Saved Data or Calibration Date

1. Press the Recall button once.
2. The display will show “Stor” and “Cal”. Use the Arrow buttons to select the desired function. *To cancel recalling information press the Recall Key and use the Up/Down Arrow Keys to select “Yes” and press the Scroll/Enter Key.*

Stor - Selecting “Stor” allows you to display the information in a memory location.

1. Press the Recall button once. The display will show “Stor” and “Cal”. Using the Arrow buttons select “Stor” by making it blink. Press the Scroll/Enter button.
2. “Addr” will be displayed and a number from 0 to 49 will flash.
3. Using the up and down arrows, select the memory location of the readings you want to display.
4. Press the Scroll/Enter key once. The 709R will display the date and time screen showing when that reading was stored.
5. Use the up and down arrows to scroll through the data that was saved.
6. Press the Scroll/Enter button and “End” will be displayed and “Yes” will flash. Press the Scroll/Enter button if you are finished recalling data or use the Arrow buttons to select No to recall data from other locations.

CAL - Selecting “CAL” allows you to display the last date of calibration.

1. Press the Recall button once. The display will show “Stor” and “Cal”. Using the Arrow buttons select “Cal” by making it blink. Press the Scroll/Enter button.
2. “CAL” will blink and the last calibration date will be displayed in DD/MM.YYYY format.
3. Press the Scroll/Enter button, “End” will be display and YES will blink. Press the Scroll/Enter button to return to normal operation.

9. PRINTING DATA

WARNING: - To operate correctly there must be a clear line of sight between the Infrared Window on the instrument (see 3.3) and the Infrared Window on the IR Printer (see Printer instructions). Place the printer so it is no closer than approximately 6 inches from the analyzer.

1. Press the Print Key once 'rEAL', "Stor", and "Cal" will be displayed and 'rEAL' will be flashing. *To cancel printing press the Print Key and use the Up/Down Arrow Keys to select "Yes" and press the Scroll/Enter Key.*

Selecting 'rEAL' will cause the 709R to print the test data currently on the display (real time data). Selecting 'Stor' will cause the 709R to print data stored in memory. Selecting "Cal" will cause the 709R to print the last date of calibration. Use the Up and Down Arrow Keys to select the desired print mode and press the Scroll/Enter Key.

REAL Print Mode - If rEAL print mode is selected, the analyzer will display 'Wait' 'out' and bars will change position on the LCD until printing is complete.

STOR Print Mode - If Stor mode is selected, 'Addr' will be displayed on the top line along with 'SA ' and a location number from 0 to 49 will be flashing on the screen. Select the required address location that you wish to print data from by pressing the Up and Down Arrow Keys and press the 'Scroll/Enter' Key. The analyzer will display 'Wait', 'out' and bars will change position on the LCD until printing is complete.

CAL Print Mode - If Cal print mode is selected, the analyzer will display 'Wait' 'out' and bars will change position on the LCD until printing is complete.

After printing is complete, 'End' will be displayed and 'YES' (or 'no') will blink. Selecting 'YES' will return the 709R to normal operation, selecting 'no' will return the 709R to the print selection screen so you can print again. Use the Up and Down Arrow Keys to make the selection and press the Scroll/Enter Key.

Combustion and pressure/draft printouts must be performed separately. Perform a combustion test and save the data. Perform a pressure/draft test and save the data in a different address. Print each address separately.

PRINTING DATA (Continued)

Printout Interpretation

Date : 07/07/06
Time : 14:22

Date and time of combustion test.

Fuel : Natural Gas

Fuel type selected during test.

----- Report -----
CO (ppm) 30
O2 (%) 3.9
CO2 (%) 9.7
Ratio (CO/CO2) .0001
CO Air Free (ppm) 37
Excess Air (%) 22.9
Gross Effi (%) 78.9
Temp_CH1 (F) 350
Temp_CH2 (F) 74

Data from combustion test is printed here.

Smoke : 1 2 3 4 5

Smoke Test Result. For use on oil fired equipment.

(Circle one to indicate the result of a smoke test performed using the optional A788 smoke test pump.)

Customer:

Address:

Reading Accepted by:

Customer information and signed confirmation of test.

(Fill in this data and have the customer sign for confirmation.)

14:22, 07/07/06

Appendix A : SPECIFICATIONS

Instrument

Operating Temperature Range	14°F to +122°F (-10°C to +50°C)
Battery	1.5V AA size (3)
Battery Life	> 6 Hours
Fuels	Natural Gas, LPG, Light Oil, Heavy Oil OPT 1 (Bituminous Coal), OPT 2 (Anthracite Coal), OPT 3 (Coke), OPT 4 (Butane), OPT 5 (Wood), OPT 6 (Bagasse)
Display	Backlit LCD
Data Storage	50 sets of readings
Time & Date	24 Hour Real Time Clock
Dimensions	200mm x 90mm x 60mm
Weight	500g
Casing	Rubber Boot as Standard
Switch Off	Failsafe
Exhaust	Safety Spigot
Conforms to	BS7927 (and the draft BS7967)

Flue Temperature Probe

Construction	Pistol Grip with Stainless Steel Shaft
Hose Length	2500mm
Insertion Length	200mm
'K' Type Thermocouple Accuracy	+/- 0.3%, +/- 1°C
Maximum Temperature	800°C

Gases

	Range	Resolution	Accuracy
Oxygen	0-25%	0.1%	+/- 0.3%
Carbon Monoxide	0-10,000 ppm	1 ppm	+/- 5 ppm or 5% Whichever is greater
Carbon Dioxide	0-25%	0.1%	Calculated
CO/CO2 Ratio	0-0.999	0.001	Calculated
Combustion Efficiency	0-100%	0.1%	Calculated

Appendix A : SPECIFICATIONS (Continued)

Pressure Measurement

Selectable Ranges	mbar, kPa and inH ₂ O
Range	- 150 mbar to + 150 mbar -15 kPa to + 15 kPa -60 inH ₂ O to 60 inH ₂ O
Resolution	0.01 mbar, 0.001 kPa, 0.001 inH ₂ O
Accuracy	+/- 0.5% fsd

Temperature Measurement

Input Type	K-Type thermocouple
Range	-58°F to 1832°F (-50°C to 1000°C)*
Resolution	1°F (1°C)
Accuracy	+/- (0.3% of rdg + 2°F) or +/- (0.3% of rdg + 1°C)

* The thermocouple supplied (GK11M) has the ability to measure temperatures in the -50°F to 950°F range. The 712 accepts industry standard K-type thermocouple probes with sub-mini connectors.

Appendix B: CALIBRATION & SERVICE

It is recommended that the instrument be calibrated every 12 months. Please consult Test Products International for further details.

The following are consumable parts for the instrument:

In-Line Filter Element (pkg of 5)	User Replaceable	A794F
Mini Pump Protection Filter Assem.	User Replaceable	A763
**Oxygen Sensor	User / Factory Replaceable	A761
**Carbon Monoxide Sensor	User / Factory Replaceable	A760
<i>**Sensor replacement requires calibration gas.</i>		

The following are accessories for the instrument:

Flue Temperature Probe w/k-type	Standard	A770
'K' Type Temperature Probe	Standard	GK11M
In-Line Filter Complete	Standard	A794
Mini Pump Protection Filter Assem.	Standard	A763
Rubber Boot	Standard	A765
Infrared Printer	Optional	A740
Soft Carrying Case	Standard	A768
Exhaust Spigot	Standard	A764

Appendix C: GUARANTEE

Your TPI 709R Flue Gas Analyzer is guaranteed free from defects in materials and workmanship for 3 Years from the date of purchase. This guarantee does not affect your statutory rights. For additional information please refer to the included warranty card or contact TPI at 800-368-5719.

To obtain warranty performance or maintenance on your analyzer: - Include with the product your name, address, phone number, written description of the problem and proof of purchase date. Carefully package and return to:

TPI / Attn. Repair
9615 SW Allen Blvd. Suite 104
Beaverton, OR 97005

Appendix D: INSTALLING THE OPTIONAL A773 OIL FILTER

When performing combustion tests on oil fired equipment it is important to use the optional A773 oil filter to ensure stable readings. The A773 does not have to be removed when working with other types of fuels.

PROCEDURE

1. Pull the yellow thermocouple out of the cord channel in the tubing up to the cord stop.
2. Cut the tubing approximately 1 1/2 inches from the end of the A762 water trap / filter assembly.

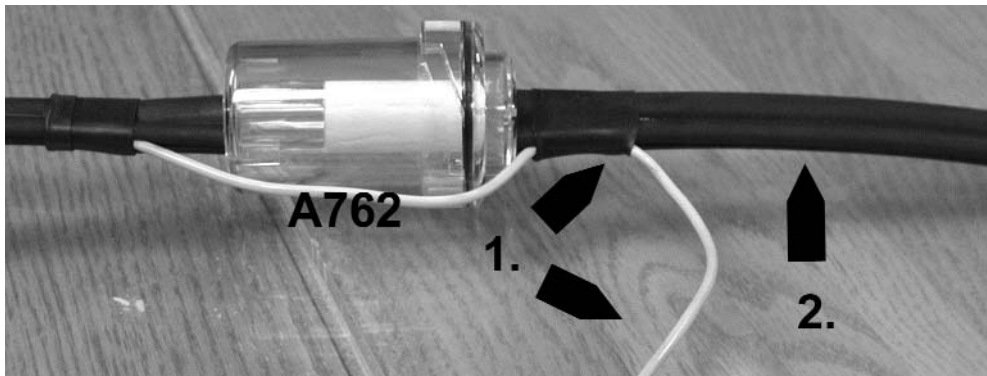

3. Insert the A773 oil filter into the tube below the A762.
4. Cut the remaining piece of tube into a 1 1/2 inch piece and connect it onto the end of the A773 oil filter.
- 5.. Press the thermocouple cord into the cord channel.

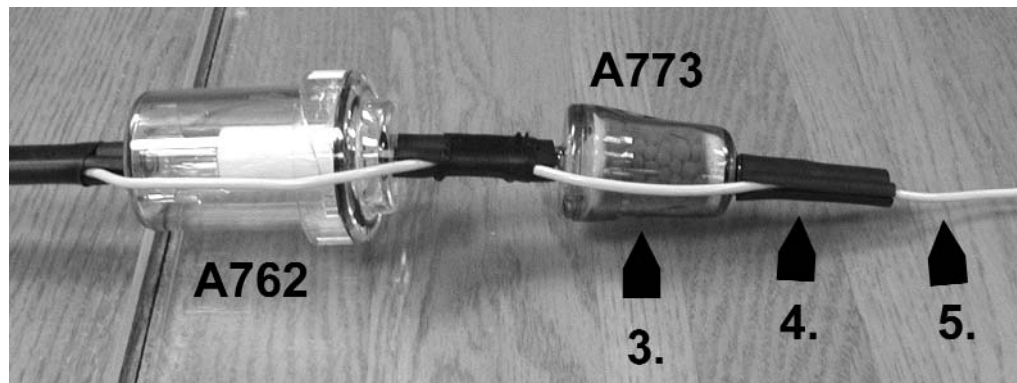

The A773 should be replaced when most of the pellets become discolored.

Appendix E: ERROR CODES & TROUBLESHOOTING

The 709R analyzer will display certain codes to let you know of a malfunction.

Code Displayed	Code Definition	Possible Causes	Corrective Action
Flo Err	Pump not drawing sample at correct flow rate.	Blockage / kink in flue probe hose. Dirty or blocked filter(s). Worn pump.	Check and rectify. Replace filter(s). Return to TPI for service.
Int O2 Err	Oxygen sensor failed to initialize	Flue probe connected to 709R prior to power up. 709R did not purge completely from last sample. Worn or defective oxygen sensor.	Disconnect probe and restart. Purge for 20 minutes and restart. Return to TPI for sensor replacement or install new sensor.* Try manually initializing the sensor. See Appendix G.
Int CO Err	Carbon monoxide sensor failed to initialize.	Flue probe connected to 709R prior to power up. 709R did not purge completely from last sample. Worn or defective carbon monoxide sensor.	Disconnect probe and restart. Purge for 20 minutes and restart. Return to TPI for sensor replacement or install new sensor.* Try manually initializing the sensor. See Appendix G.
Lo bat	Low battery.	Battery needs to be charged.	Charge battery. If the battery won't hold a charge, replace the battery.
oFL	Overflow indication. The carbon monoxide being measured is above the instruments capability.	CO being measured is too high or low.	Remove the CO source and allow the 709R to purge.
oFL	Overflow indication. The temperature being measured is outside the maximum measurement capability.	Temperature being measured is too high or low.	Remove pressure source.
oPEn	Unable to read thermocouple (temperature).	Temperature probe not connected to input. Worn temperature sensor.	Connect temperature probe to analyzer. Replace temperature probe or flue probe.

*Sensor replacement requires calibration gas.

Appendix E: ERROR CODES & TROUBLESHOOTING (Continued)

Problem	Possible Cause	Corrective Action
Efficiency reading incorrect	<p>NET efficiency selected.</p> <p>Ambient temperature probe not plugged in to T2.</p> <p>Incorrect fuel selected.</p>	<p>Select GROSS efficiency. See section 5.3.</p> <p>Plug ambient probe into T2. See section 5.2.</p> <p>Select the proper fuel for the equipment being tested. See section 4.1.</p>
Readings are erratic when working on oil fired equipment.	A773 oil filter not installed or installed incorrectly.	Make sure the optional oil filter (A773) is installed. See Appendix D.
One or all of the following parameters; Ratio, CO air free, excess air, and efficiency read and print dashes.	Measured values are such that the calculated values of these parameters are out of range.	<p>Redo combustion test. Since these are calculated values, the measure values must be within certain levels for these to display. If the measured oxygen level is above 19.9% these parameters won't read.</p> <p>These parameters might not display or be applicable in some tests.</p>
Analyzer won't turn off	Oxygen and/or carbon monoxide levels outside limits.	Allow the analyzer to purge longer.

Appendix F: CO ALARM & AUTO OFF SETTINGS

Setting the Carbon Monoxide Alarm Point and/or Auto Power Off Mode

The CO alarm and auto power off settings can be changed as necessary by performing the following procedure.

WARNING : Changing parameters in field calibration mode can adversely affect the operation of your analyzer. Follow the instructions carefully.

1. Press and hold the Scroll/Enter Key down until 'FILD CAL' is displayed. The 709R will cycle through a 30 second countdown then display 'CAL', 'Air', 'gAS'.
2. Use the Up Arrow Key to select 'Air' by making it blink. Press the Scroll/Enter Key to accept the selection.
3. 709R Display: 'CAL', 'FLo', 'oPEn'. Action : Press the Func Key to bypass.
4. 709R Display: 'CAL', 'FLo', 'CLoS'. Action : Press the Func Key to bypass.
5. 709R Display: '0ppm', 'Co', 'rEF'. Action : Press the Func Key to bypass.
6. 709R Display: '20.9%', 'o2', 'rEF'. Action : Press the Func Key to bypass.
7. 709R Display: '2000', 'A-r', 'SEt'. Action : If you are not changing the CO alarm point press the Func Key. Otherwise press the Up and Down Keys to set the ppm level the alarm will sound at. Factory default is 2000ppm. Press the Scroll/Enter Key to accept the selection.
8. 709R Display: 'Auto', 'oFF', 'En'. Action : If you are not changing the auto power off mode press the Func Key. Otherwise press the Up and Down Arrow Keys to enable (En) or disable (dis) the auto off function. Factory default is enabled (En). Press the Scroll/Enter Key to accept the selection.
9. 709R Display: 'CAL', 'StoP', 'go'. Action : Press the Up Arrow Key to select 'StoP' by making it blink and press the Scroll/Enter Key to accept the selection. The 709R will return to normal operation

Appendix G: MANUALLY INITIALIZING SENSORS

Manually Initializing the Carbon Monoxide and Oxygen Sensors

If the CO or O₂ sensor fails to initialize, this procedure can be performed to try and manually initialize the sensor(s).

WARNING : Changing parameters in field calibration mode can adversely affect the operation of your analyzer. Follow the instructions carefully.

1. Press and hold the Scroll/Enter Key down until 'FIELD CAL' is displayed. The 709R will cycle through a 30 second countdown then display 'CAL', 'Air', 'gAS'.
2. Use the Up Arrow Key to select 'Air' by making it blink. Press the Scroll/Enter Key to accept the selection.
3. 709R Display: 'CAL', 'FLo', 'oPEn'. Action : Press the Func Key to bypass.
4. 709R Display: 'CAL', 'FLo', 'CLoS'. Action : Press the Func Key to bypass.
5. 709R Display: 'Oppm', 'Co', 'rEF'. Action : Press the Scroll/Enter Key. After the 10 second countdown is complete press the Scroll/Enter Key twice.
6. 709R Display: '20.9%', 'o2', 'rEF'. Action : Press the Scroll/Enter Key. After the 10 second countdown is complete press the Scroll/Enter Key twice.
7. 709R Display: '2000', 'A-r', 'SEt'. Action : Press the Func Key to bypass.
8. 709R Display: 'Auto', 'oFF', 'En'. Action : Press the Func Key to bypass.
9. 709R Display: 'CAL', 'StoP', 'go'. Action : Press the Up Arrow Key to select 'StoP' by making it blink and press the Scroll/Enter Key to accept the selection. The 709R will return to normal operation

If the 709R continues to fail to automatically initialize or this procedure fails to initialize the sensors, return your analyzer to Test Products International.

Appendix H: RESETTING PRESSURE SENSOR ZERO

Manually resetting the pressure sensor zero point

If the pressure sensor will not zero as described in section 6.2 use the procedure below to reset the zero point of the sensor.

WARNING : Changing parameters in field calibration mode can adversely affect the operation of your analyzer. Follow the instructions carefully.

1. Press and hold the Scroll/Enter Key down until 'FILD CAL' is displayed. The 709R will cycle through a 30 second countdown then display 'CAL', 'Air', 'gAS'.
2. Use the Up Arrow Key to select 'Air' by making it blink. Press the Scroll/Enter Key to accept the selection.
3. 709R Display: 'CAL', 'FLo', 'oPEn'. Action : Press the Func Key to bypass.
4. 709R Display: 'CAL', 'FLo', 'CLOs'. Action : Press the Func Key to bypass.
5. 709R Display: 'CAL', 'LEAK', 'rEF'. Action : Press the Func Key to bypass.
6. 709R Display: '0ppm', 'Co', 'rEF'. Action : Press the Func Key to bypass.
7. 709R Display: '20.9%', 'o2', 'rEF'. Action : Press the Func Key to bypass.
8. 709R Display: '0.0mbar', '0.0', 'oFS'. Action : Press the Func Key to bypass.
9. 709R Display: '2000', 'A-r', 'SEt'. Action : Press the Func Key to bypass.
10. 709R Display: 'Auto', 'oFF', 'En'. Action : Press the Func Key to bypass.
11. 709R Display: 'CAL', 'StoP', 'go'. Action : Press the Up Arrow Key to select 'StoP' by making it blink and press the Scroll/Enter Key to accept the selection. The 709R will return to normal operation

If the 709R continues to fail to automatically initialize or this procedure fails to initialize the sensors, return your analyzer to Test Products International.

Appendix I: Technical Notes

Note 1: When performing a pressure or draft test during a combustion test, the pump can be turned on to provide a continuous sample to the sensors. This enables pressure adjustments to be made and the affect to the combustion process can be seen by returning to combustion analyzer mode. Use the FUNC Key to activate manometer mode. Press and hold the Up Arrow Key until the pump reactivates. Perform a pressure test and then use the FUNC key to activate combustion analyzer mode. Repeat this process until pressure adjustments are complete.

Note 2: Several factors affect combustion efficiency. Dirty or clogged air filters reduce the amount of air available for combustion therefore reducing efficiency. Obstructions in the flue block exhaust gases and alter the air mixture in the combustion chamber which reduces efficiency. Air leaks in the combustion chamber also alter the mixture causing decreased efficiency.

Note 3: The primary way to affect change in combustion efficiency when working with modern gas fired equipment is through gas manifold pressure adjustment. Confirm manifold pressures are within maufacturers specifications prior to performing a combustion test. Once manifold pressures are within limits a combustion test can be performed to provide information regarding any adjustments that may be needed.

Notes:

Notes:

Notes:

Test Products International, Inc.

9615 SW Allen Blvd., Ste. 104

Beaverton, OR 97005

Tel: 503-520-9197 Fax: 503-520-1225

www.tpi-thevalueleader.com

Test Products International, Ltd.

342 Bronte Road South, Unit #9

Milton Ontario Canada L9T5B7

Tel: 905-693-8558 Fax: 905-693-0888